



FOAM PROPORTIONING EQUIPMENT

HYDRAULICALLY ACTUATED VALVE

DESCRIPTION

WARNING!

THE ACTUATOR IS PROVIDED WITH A WATER INLET SHUT-OFF VALVE TO FACILITATE THE RESETTING OF THE VALVE AFTER ACTUATION. ENSURE THAT THIS VALVE IS LEFT OPEN WHEN SYSTEM IS PLACED INTO SERVICE. FAILURE OF THE SYSTEM COULD RESULT IF THE VALVE IS LEFT CLOSED.

The standard hydraulic concentrate control valve assembly consists of a factory assembled and tested quarter turn full port ball valve to which a hydraulic actuator has been attached. The ball valve has a bronze body with 316 stainless steel ball and stem. Valve seats are glass reinforced bronze. Inlet and outlet threads are female NPT. All valves are rated 600 psig WOG. Stainless steel flanged valves are rated in excess of 1,000 psig WOG.

The hydraulic actuator is mounted directly to the ball valve using a mounting bracket. The housing of the actuator has a corrosion resistant exterior with a two-part epoxy coating providing extra protection against aggressive environments. The interior components have Oeramiguard, a unique finish of Di-Aluminum Tri-Oxide; a hard ceramic like surface, protecting all body parts against wear and corrosion. The actuator has two way rotational travel stops, providing a minimum of 96° and positive, adjustable rotation stopping (10° at each end.) This combination assures positive sealing, correct port alignment for long valve life and maximum foam concentrate flow through the ball valve. The hydraulic actuator is equipped with a visual valve position indicator and has the capability for manual override using a free handle, secured to the valve body with a length of chain. Water to drive the valve open is fed to the hydraulic actuator through 1/4 inch or 3/8 inch pipe or copper tubing. A connection from the sprinkler system is usually made from a normally un-pressurized port, such as the water motor alarm line on the alarm or deluge valve to power the hydraulic actuator. The water inlet to the hydraulic actuator will be provided with a 1/2" strainer and shut-off valve to allow depressurizing and resetting of the valve after use. In the event electric operation is required or preferred, a solenoid release is installed in the water supply line to the actuator which will, on system actuation allow water to flow into the actuator body and open the valve.

APPLICATION

The Buckeye Hydraulic Concentrate Control Valve is designed for use with either a bladder tank or an in-line balanced pressure proportioning system. The valve is used to automatically open the line supplying foam concentrate to a ratio controller. It does not require electrical power to operate, only water pressure from the system that has been activated.

FEATURES

- Six different size assemblies available.
- Minimum operating pressure 35 psi with a recommended maximum pressure of 120 psi.
- Maximum overload pressure 150 psi.
- Durable corrosion resistant finish.
- Actuator has easy stop adjustments at each end of stroke for accurate seating of the ball.

ORDERING INFORMATION

Part No.	Valve Size
BFHAV-1.0	1" Hydraulically Actuated Valve
BFHAV-1.25	1-1/4" Hydraulically Actuated Valve
BFHAV-1.5	1-1/2" Hydraulically Actuated Valve
BFHAV-2.0	2" Hydraulically Actuated Valve
BFHAV-2.5	2-1/2" Hydraulically Actuated Valve
BFHAV-3.0	3" Hydraulically Actuated Valve

OPTIONS

- 24V DC or 120V AC Solenoid
- Stainless steel flanged ball valve





FOAM PROPORTIONING EQUIPMENT

HYDRAULICALLY ACTUATED VALVE

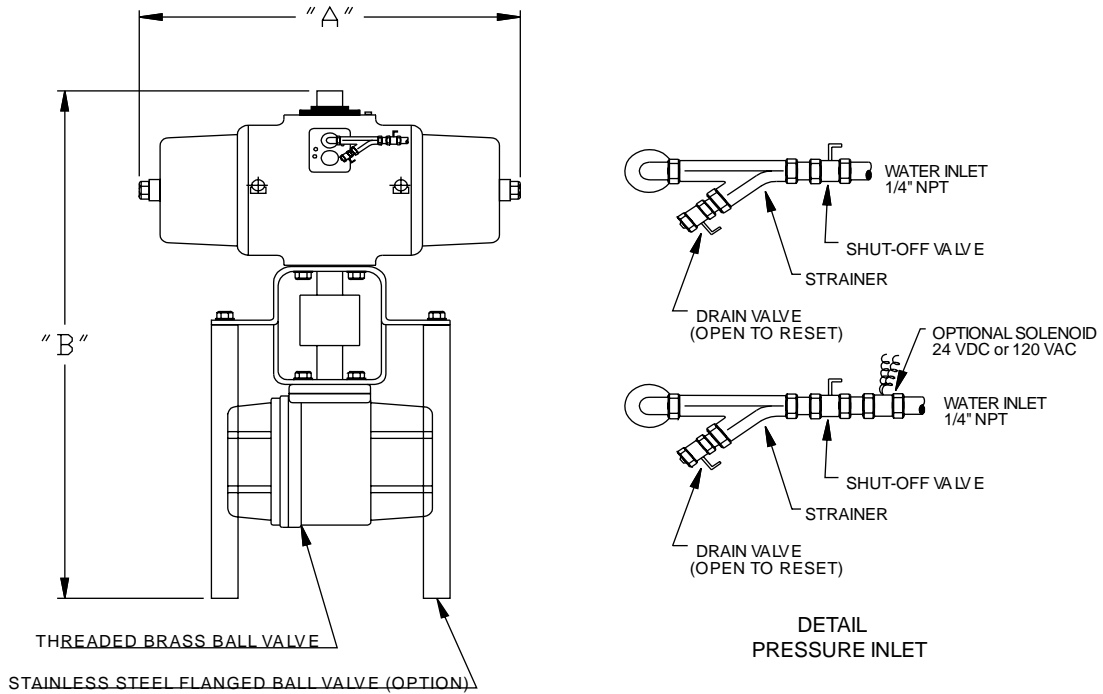

VALVE	ACTUATOR	THREADED		FLANGED	
		A	B	A	B
1"	XL - 26DA/XL - 71DA	6.5" (165 mm)	6.5" (165 mm)	8.75" (222 mm)	10.5" (267 mm)
1 1/4"	XL - 71DA	8.75" (222 mm)	8.5" (216 mm)	8.5" (216 mm)	11" (280 mm)
1 1/2"	XL - 71DA/XL - 131DA	8.75" (222 mm)	9.5" (241 mm)	11.5" (295 mm)	11.5" (295 mm)
2"	XL - 131DA/XL - 186DA	11.5" (295 mm)	10" (254 mm)	13.0" (330 mm)	13.5" (420 mm)
2 1/2"	XL - 186DA	9.5" (242 mm)	13.5" (343 mm)	13.0" (330 mm)	16.5" (420 mm)
3"	XL - 221DA/XL - 280DA	13.75" (350 mm)	9.5" (241 mm)	10" (254 mm)	18.5" (470 mm)

